



# PHARMA MACHINERIES



**COMMUNITING MILL GMP MODEL**



### TYPE OF SCREENS AVAILABLE :

- TYPE 'A' SCREENS -** Perforated Round Holes :  
 3/32", 7/64", 1/8", 5/32",  
 3/16", 7/32", 1/4", 5/16",  
 3/8", 1/2", 5/8", 3/4" and 1".  
 Perforated Square Holes :  
 1/4", 3/8", 1/2", 7/8"  
 and 1 1/8".
- TYPE 'B' SCREENS -** Perforated Round Holes  
 with back reinforcing plate :  
 1/50", 1/42", 1/37", 1/32",  
 1/25", 1/20" and 1/16".
- TYPE 'C' SCREENS -** Woven Stainless Steel Wire  
 Mesh with back reinforcing  
 plate : 3, 6, 8, 10, 12, 14, 16,  
 20, 30, 40 and 50 mesh.
- TYPE 'D' SCREENS -** Woven Stainless Steel Wire  
 Mesh mounted on front and  
 back reinforcing plate of 36  
 Square Holes : 60, 80 mesh.
- TYPE 'E' SCREENS -** Woven Stainless Steel Wire  
 Mesh mounted on front and  
 back reinforcing plate of 36  
 Square Holes : 100, 200 Mesh

Perforated screens are also available with Holes size in mm.

FRONT VIEW

SIDE VIEW

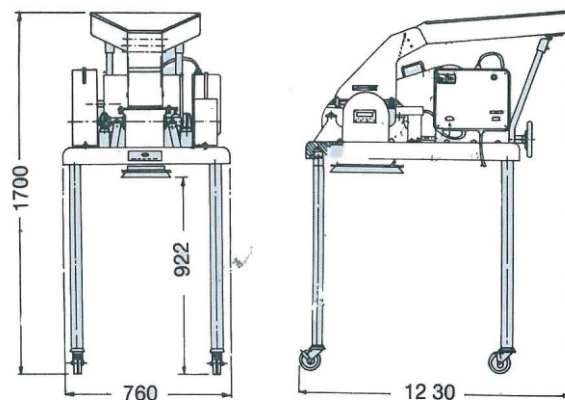

ALL DIMENSIONS ARE IN MM

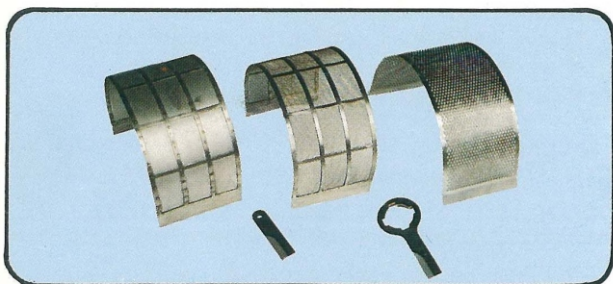
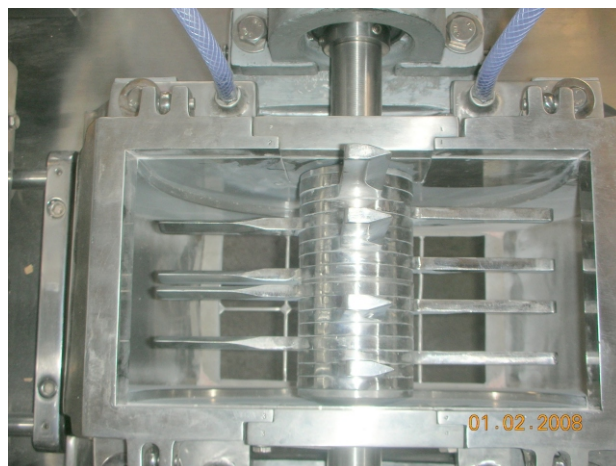

## RIDDHI PHARMA MACHINERY LTD.

**Manufacturer & Exporters of Pharmaceutical Machineries**

**OFFICE: MUMBAI** Om-Shivam Bldg.,2, Tarun Bharat, Sahar Rd, Andheri(E), Mumbai-400 099.Maharashtra, India.

Tel.: 91-22-2832 1332 / 2838 9432 Fax: 91-22-2838 2479 Res : 91-22-2683 3777, Mob: 98210 18579

**Whatsapp :** 919821018579 **Skype :** hiten.k.shah

**E-mail:** hitenkshah@hotmail.com/ hitenks@vsnl.com **Website:** www.riddhipharma.com

**FACTORY :** Riddhi Estate, Gulab Nagar, Opp. AEC, Amraiwadi, Ahemdabad-380 026. India.



## **RIDDHI MILL COMMINUTING MACHINE PLAIN & WATER JACKETED MODEL : RDFM**

APPLICATION :Riddhi mill has been specifically designed for wet and drygranulation, pulverization or dispersion of products oringredients found in the pharmaceutical, Chemical and foodindustries.It is also finds application in Cosmetics,confectionery, Fertilizers, Insecticides, detergents andElectroflux Industries etc.

DESCRIPTION :Latest improvements in design makes this unit a truly GMP model and Versatile in operation & maintenance.

Unit consist of S.S.304 quality hopper, feed throat andprocessing chamber (can be provided in S.S.316 quality atextra cost ) with beaters assembly , heavy duty motor, star deltastarter with overload relay, three speed step pulley, suitable screen , S.S. cladded base having tubular legs with castors,

optional jacket for the feed throat and processing chamber forcooling.OPERATION :Product kept in the hopper slide down to the enclosedchamber, where it is milled in between beaters and screento the required mesh/micron size which can be collectedat the bottom of the container.Quality and output depends upon the three main variables1) Beaters shape (knife/impact forward)2)Speed and

3)Screen size.Knife edge for coarse or large particles and impact or flatedge for finer particles. Highspeed for fine griding, lowspeed for coarser particles. A wide range of screens isavailable for various process needs.

### TECHNICAL SPECIFICATION

OUTPUT	: 50 kgs. to 800 kgs per hour depending on the product and the reduction required in size.
ROTOR SPEED	: 1000/2250/4500 RPM.
BEATERS	: 16 NOS Stainless steel with knife and impact edges
SCREEN AREA	: 495 mm x 135 mm (66825sq.mm)
MOTOR	: 7.5HP/1400RPM/440V/50CS/3PH/AC.
STARTER	: Star Delta with no-load and overload protection.
NET WEIGHT	: 400 kgs.
GROSS WEIGHT	: 530 kgS.
DIMENSIONS	: 1230 x 760 x1575 MM(HT)49 x30 x62 inch app.
CASE DIMENSIONS	: 1380 x1050 x1900 MM(HT) 55 x 42 x 75 inch

## **RIDDHI PHARMA MACHINERY LTD.**

### **Manufacturer & Exporters of Pharmaceutical Machineries**

**OFFICE: MUMBAI** Om-Shivam Bldg.,2, Tarun Bharat, Sahar Rd, Andheri(E), Mumbai-400 099.Maharashtra, India.

Tel.: 91-22-2832 1332 / 2838 9432 Fax: 91-22-2838 2479 Res : 91-22-2683 3777, Mob: 98210 18579

**Whatsapp** : 919821018579 **Skype** : hiten.k.shah

**E-mail:** hitenkshah@hotmail.com/ hitenks@vsnl.com **Website:** www.riddhipharma.com

**FACTORY** : Riddhi Estate, Gulab Nagar, Opp. AEC, Amraiwadi, Ahemdabad-380 026. India.